



Rectangular ducting 2022

About the products

General

The present catalogue contains information materials about rectangular ducts and fittings produced by us. The products are made according to standard EVS-EN 1505. Standard products are made of hot-dip galvanized sheet steel. We also make products of other materials, if necessary. Products made of stainless or aluzinc sheet steel have better protection against corrosion and are more durable. If necessary, we also produce ducts and fittings not available in the catalogue, according to drawings.

Tolerances

L tolerance of the straight ventilation duct is $\pm 0.005L$

Angle tolerance $\pm 2^\circ$.

Tolerances of values a, b, c, d, e and s range 0-4 mm.

Measurements

The nominal dimension of rectangular duct and fittings are inner dimension of the sides of the pipe a and b in millimetres. a marks the visible side. For the reducer of rectangular duct, the dimensions of the smaller end are shown with letters c and d, where c marks the visible side.

Dimension l marks the useful length which influences the total length of the channel system upon installation.

It is possible to order the duct and the fittings with side dimension 150–2500 mm.

Joinings

For joining the ventilation ducts and the fittings, the products are supplied with a joining profile (Z-profile is used as a standard solution). It is also possible to order products with europrofile and flange profile.

If a ventilation system is mounted according to the installation instruction, it is possible to achieve the following tightness with various fittings of the ducting of Metaline by different connection methods:

- Z-profile connection, class C
- euro profile connection, class D
- flange connection, class D (welded ducting)

Rectangular ducting

www.metaline.ee

VKK



VKP 90



VKP 45



VKI



VKE



VKC



VKR



VKD



VKX



VKT



VKS



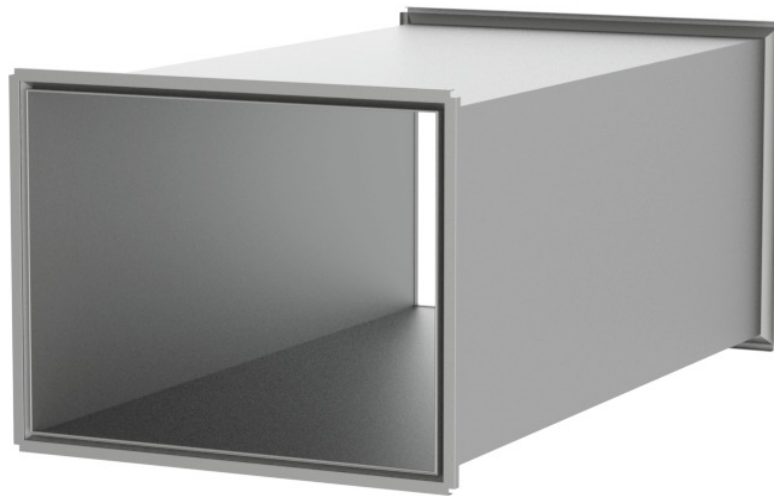

VKK duct

Description

VKK rectangular duct where both ends are supplied with a joining profile (z-profile) as a standard. Depending on the size of the duct, it is stiffened with rods and corner bits.

1. Duct is stiffened with rods and corner bits (standard):
 - $600 < a, b < 1200$ 1 rod and 1 corner bit at both ends
 - $1200 \leq a, b \leq 1600$ 2 rods and 2 corner bits at both ends
 - $1600 < a, b \leq 2400$ 3 rods and 2 corner bits at both ends
2. U-corrugated duct has outside stiffening profiles with installation height of 20 mm.
 - $a, b \leq 600$
 - $600 < a, b \leq 1200$
 - $a, b > 1200$

Marking of the product

1. Marking
2. Material
 - ZN: Galvanized steel (standard, not marked)
 - AZ: Aluzinc steel
 - R: Stainless steel
 - H: Acid-proof steel
3. a - Width
4. b - Height
5. l - Length
 - if a or $b \leq 1200$, then $l = 1250$ or 2000 mm.
 - if a or $b > 1200$, then $l = 1250$ mm

Example

VKK	-R	500	x	300	L-1250
1	2	3		4	5

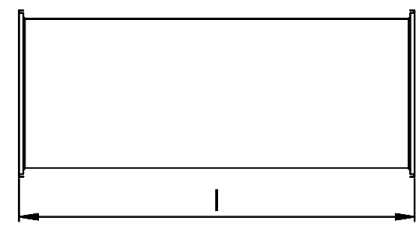
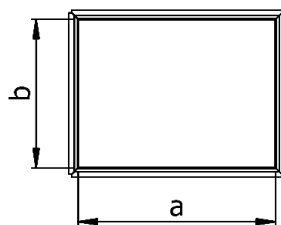



VKP 90° bend

Kirjeldus

Both ends of VKP bend are supplied with a joining profile (z-profile).
 If the length of side $a > 600$ mm, bend is stiffened with a guide blade.
 Standard radius $r = 125$ mm. Standard angle $\alpha = 90^\circ$.

Marking of the product

1. Marking
2. Material
 - ZN: Galvanized steel (standard, not marked)
 - AZ: Aluzinc steel
 - R: Stainless steel
 - H: Acid-proof steel
3. Angle - 90°
4. a - Form side
b - Curved side

Example

VKP	-R	-90	500	x	300
1	2	3	4		5

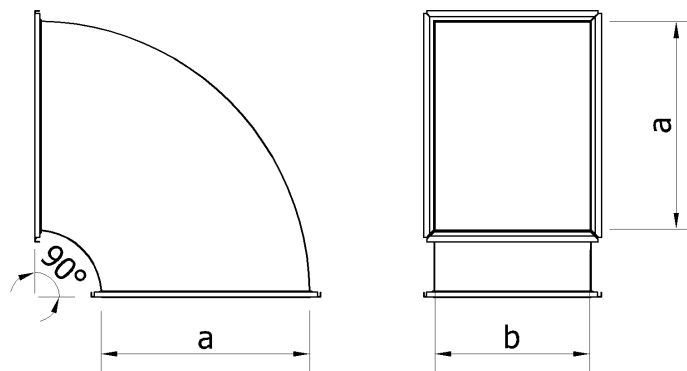



VKP 45° bend

Description

Both ends of VKP bend are supplied with a joining profile (z-profile).
Standard radius $r = 125$ mm. Standard angle $\alpha = 45^\circ$.

Marking of the product

1. Marking
2. Material
 - ZN: Galvanized steel (standard, not marked)
 - AZ: Aluzinc steel
 - R: Stainless steel
 - H: Acid-proof steel
3. Angle - 45°
4. a - Form side
5. b - Curved side

Example

VKP	-R	-45	500	x	300
1	2	3	4		5

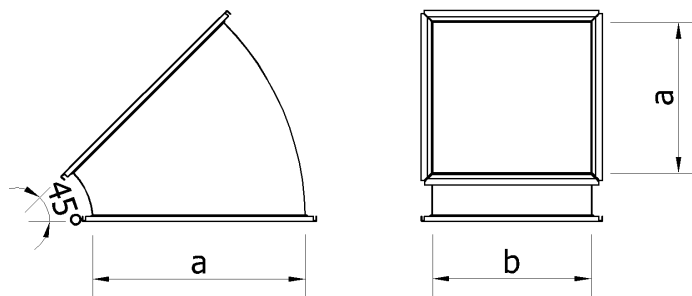



VKI saddle

Description

VKI saddle is used for connection to rectangular duct. One end of the saddle is supplied with a joining profile (z-profile). Standard length 125 mm.

Marking of the product

1. Marking
2. Material
 - ZN: Galvanized steel (standard, not marked)
 - AZ: Aluzinc steel
 - R: Stainless steel
 - H: Acid-proof steel
3. a - Width
4. b - Height

Example

VKI	-R	500	x	300
1	2	3		4

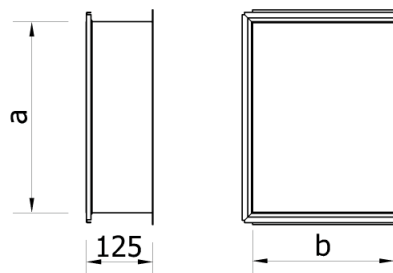

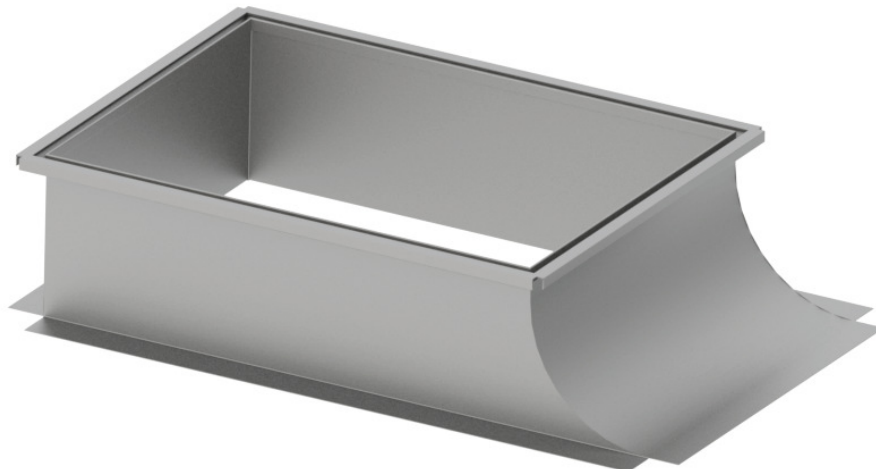

VKE saddle

Description

VKE saddle is used for connection to rectangular duct. One end of the saddle is supplied with a joining profile (z-profile). Standard length 125 mm.

Marking of the product

1. Marking
2. Material
 - ZN: Galvanized steel (standard, not marked)
 - AZ: Aluzinc steel
 - R: Stainless steel
 - H: Acid-proof steel
3. a - Width
4. b - Height

Example

VKE	-R	500	x	300
1	2	3		4

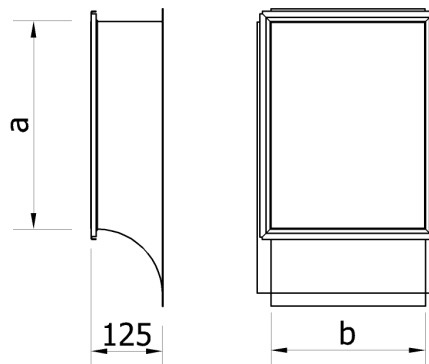



VKC saddle

Description

VKC saddle is used for connection to circular duct. The rectangular end is provided with joining profile (z-profile). The rounded end has an edge for fixing. Standard length 125 mm.

Marking of the product

1. Marking
2. Material
 - ZN: Galvanized steel (standard, not marked)
 - AZ: Aluzinc steel
 - R: Stainless steel
 - H: Acid-proof steel
3. a - Width
4. b - Height
5. d - Duct diameter

Example

VKC	-R	500	x	300	/	315
1	2	3		4		5

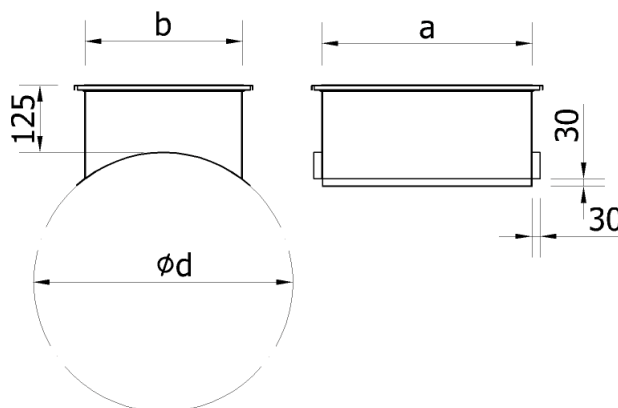

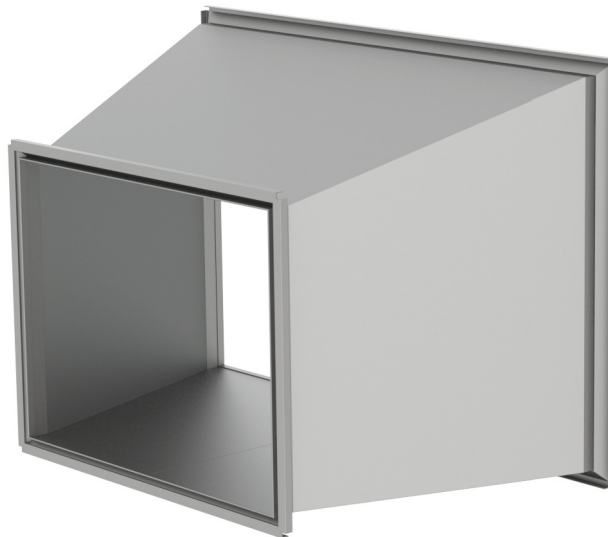

VKR reducer r/r

Description

VKR reducer are used to connect rectangular duct of different sizes. The ends of the reducer are supplied with a joining profile (z-profile).

Standard length 300 mm, if a or b < 800 mm.

Standard length 500 mm, if a or b > 800 mm.

Marking of the product

1. Marking
2. Material
 - ZN: Galvanized steel (standard, not marked)
 - AZ: Aluzinc steel
 - R: Stainless steel
 - H: Acid-proof steel
3. a - Width
4. b - Height
5. c - Width
6. d - Height
7. Eccentricity: 1,2,3,4,5
8. l - Length

Example

VKR	-R	500	x	300	/400	x	200	-1	- 300
1	2	3		4	5		6	7	8

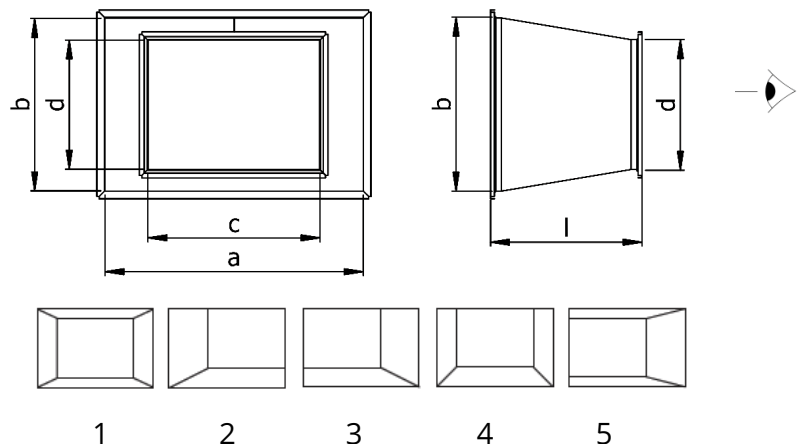

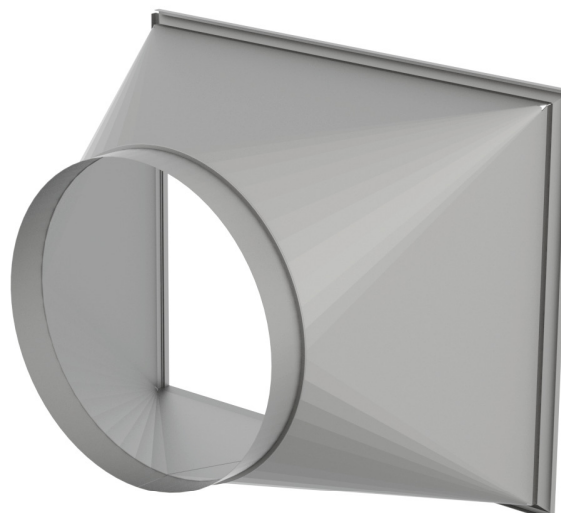

VKD reducer r/c

Description

VKD reducers are used to connect rectangular and circular ducts. The rectangular end of the reducer is supplied with a joining profile (z-profile) and the circular end is with safe seal.

Standard length 300 mm, if a or $b < 800$ mm.

Standard length 500 mm, if a or $b > 800$ mm.

Marking of the product

1. Marking
2. Material
 - ZN: Galvanized steel (standard, not marked)
 - AZ: Aluzinc steel
 - R: Stainless steel
 - H: Acid-proof steel
3. a - Width
4. b - Height
5. d - Diameter
6. Eccentricity 1,2,3,4,5
7. l - Length

Example

VKD	-R	500	x	300	/315	-1	-300
1	2	3		4	5	6	7

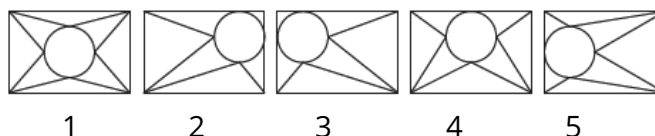
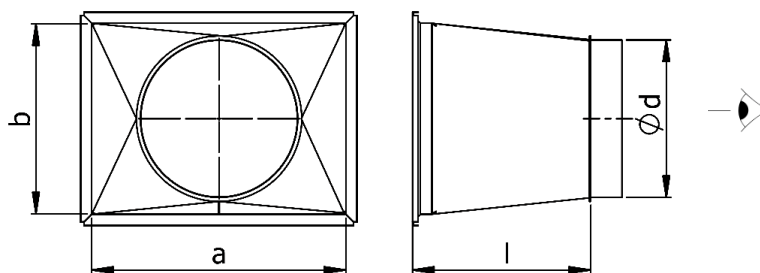



VKX end cover

Description

VKX end cover is used as and cover in duct.
The standard version of the product is without a connection strip.

Marking of the product

1. Marking
2. Material
 - ZN: Galvanized steel (standard, not marked)
 - AZ: Aluzinc steel
 - R: Stainless steel
 - H: Acid-proof steel
3. a - Width
4. b - Height

Example

VKX	-R	500	x	500
1	2	3		4

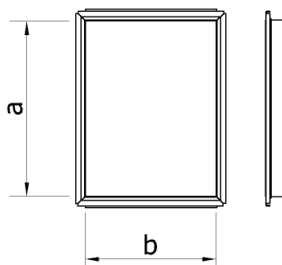

With joining profile

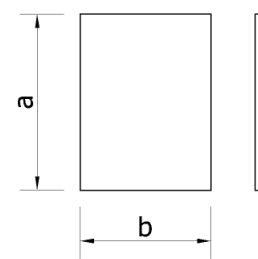

Standard - without joining profile



VKT T-piece

Description

VKT T-piece is used to divide a duct with an angle of 90°. The ends of the T-piece are supplied with a joining profile (z-profile).

Marking of the product

1. Marking
2. Materjal
 - ZN: Galvanized steel (standard, not marked)
 - AZ: Aluzinc steel
 - R: Stainless steel
 - H: Acid-proof steel
3. a - Width
4. b - Height
5. c - Height
6. d - Height

Example

VKT	-R	500	x	300	/400	/600
1	2	3		4	5	6

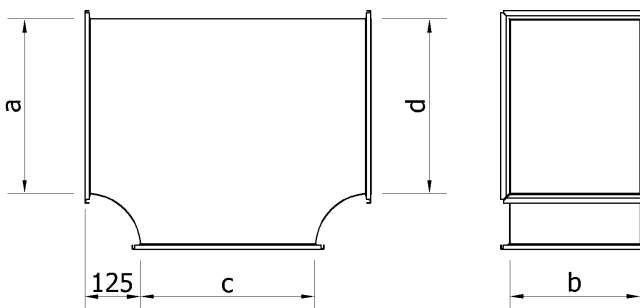



VKS S-bend

Description

VKS S-bend is used for deflections of the duct system, for example where ducts cross. Both ends of the S-bend are supplied with a joining profile (z-profile). In order to ensure the required air flow, it is recommended to choose suitable measurements for length l and offset s .

Marking of the product

1. Marking
2. Material
 - ZN: Galvanized steel (standard, not marked)
 - AZ: Aluzinc steel
 - R: Stainless steel
 - H: Acid-proof steel
3. a - Height
4. b - Width
5. s - Shift
6. l - Length

Example

VKS	-R	500	x	300	-50	-300
1	2	3		4	5	6

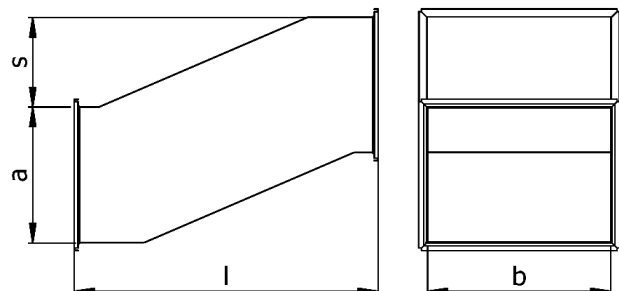



Metaline OÜ

**Marja 7,
10617 Tallinn
ESTONIA**

www.metaline.ee